

Amplitude Calibration - Measuring Antenna Temperature

R.S. Flagg, RF Associates, March 2012

The Jove radio telescope is designed to receive radio noise bursts from Jupiter and the Sun and also radio noise from our galaxy. Observers can display signals from these sources using Radio-SkyPipe software. The SkyPipe record below shows signals from Jupiter.

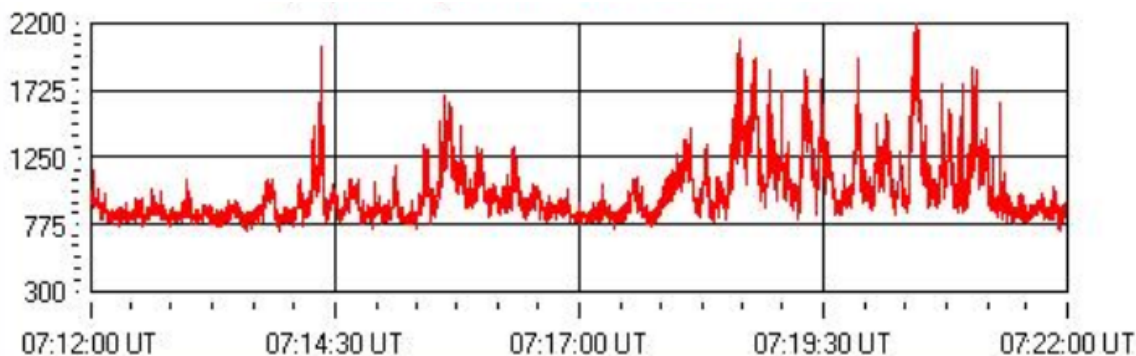

The horizontal axis is time while the vertical axis is in SkyPipe Units (SPU). For this record the receiver and software gain controls were set so that the baseline runs around 800 units on the vertical scale with the strongest burst extending up to 2200 units.

At a radio-quiet receiving site the background (baseline) noise is due primarily to emissions from relativistic electrons spiraling in the galactic magnetic field. However, signals from earth-based sources such as arcing power lines, computers, electric motors and aquarium heaters (and lots of other things) may be added to the galactic background noise. These noise sources are generally broadband in nature and you cannot tune the radio to avoid them. If the total noise background (galactic plus terrestrial sources) is too high, then signals from Jupiter and the Sun will be masked by the local noise.

In order to determine how quiet or noisy a receiving site is we need a calibrated noise source – one that generates about the same signal level as the galactic background. When substituted for the antenna, the noise source establishes a reference signal level. If the level from the antenna is about the same as this reference, then the receiving site is quiet. However, if the noise level from the antenna is several times stronger, then we know the site is noisy and may not be suitable.

Radio-SkyPipe Units (SPU)

The vertical axis of SkyPipe uses a numeric scale that can be set in the range of 0 – 32,000 when using the sound card input. The signal trace on the SkyPipe screen can be adjusted with the Jove receiver volume control and also the software volume control in Windows. By changing these gains, the trace can be moved up or down and compressed or expanded. However, there is no absolute reference point. The SkyPipe vertical scale units are relative, unit less, numbers. They are not engineering units like volts, watts, or degrees.

While the chart shows signals getting stronger or weaker, it is difficult to make comparisons with records from other observers, since they may be using different gain settings. To obtain information about the absolute strength of the signals, we need to convert SkyPipe units (SPU) into engineering units with an absolute reference. This will transform our data from qualitative to quantitative.

Once again a calibrated noise source comes to the rescue. This time it will be used to convert SPU into engineering units. But calibrated in terms of what kind of units?

Radio astronomers deal with very weak signals from the cosmos and they use special units to describe signal strength. One common unit is *antenna temperature*.

Antenna Temperature

A resistor connected to the antenna terminals of a receiver will generate a weak noise signal due to the random motion of free electrons within the resistor. If we heat the resistor up with a blowtorch (don't try this at home kids) the noise signal would increase in amplitude because of the increased thermal motion of those free electrons.

If we heat the resistor up to 25,000 kelvins then the power delivered to a receiver is about the same as from the galactic background (assuming a modest run of coax between the antenna and receiver).

Because of this relationship between the noise signal generated by a resistor and the noise signal delivered from an antenna, it is convenient to describe the antenna signal in terms of antenna temperature. In theory we could replace the antenna with a resistor and vary the temperature of the resistor until the noise power it produces matches the noise power from the cosmic radio source. When the noise power levels match we note the temperature of the resistor. This value of temperature is called *antenna temperature*.

Measuring Antenna Temperature

Fortunately, instead of a resistor and a blowtorch we can use a solid-state noise source that generates known noise temperatures. With such a device we can rescale SkyPipe so that the vertical axis is in absolute units of antenna temperature.

SkyPipe units are not volts but they are proportional to voltage. When the signal voltage from the Jove receiver to the soundcard doubles then the SPU will also double. This is true over a reasonable range of voltages for several soundcards which have been tested, (however, it may not be true for all soundcards).

Linear and Non-linear Operation

The Jove receiver exhibits linear operation over a fairly wide range of signal strengths. This means that if the input doubles in strength then the output will also double. However, at some point the output can no longer follow the input. In this non-linear region the receiver is said to be saturated or in compression.

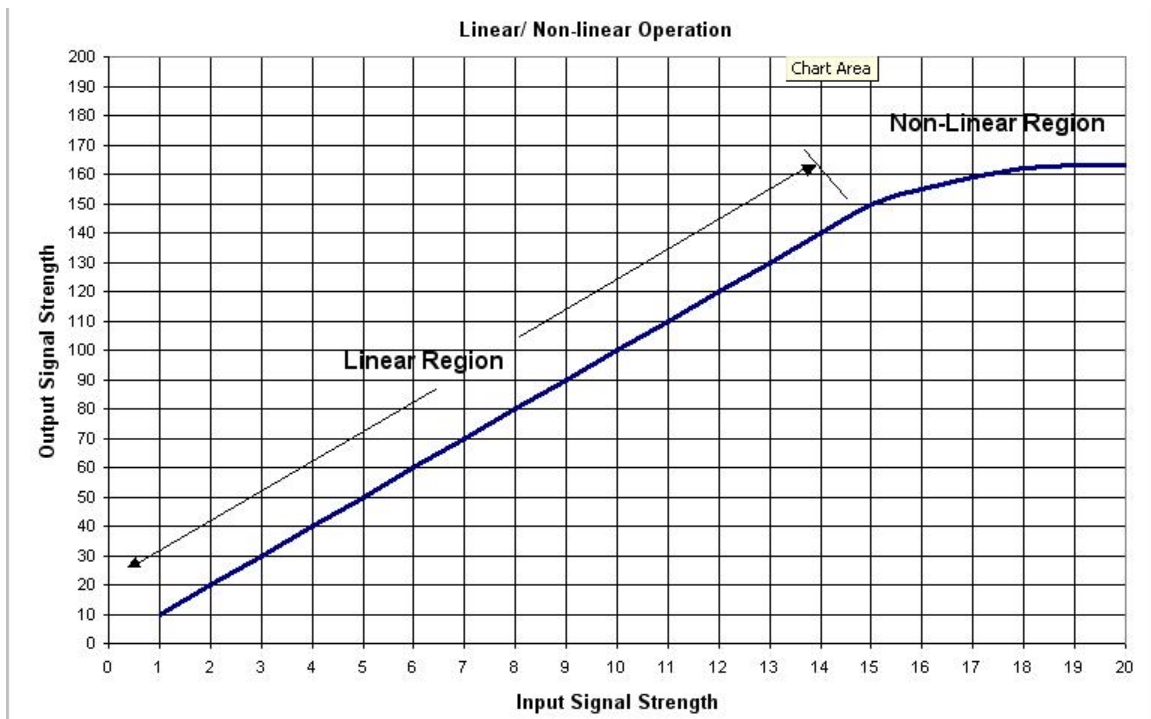

In the linear region we can calibrate the system at a single point. Calibration means measuring the SPU for a known noise temperature at the receiver antenna terminals. A simple equation relates SPU to temperature for all other signals in the linear region. However, if signals go into compression then the calibration is no longer valid.

Dynamic Range

The minimum signal we encounter is the galactic background. The maximum signal level is just before going into compression. The ratio of the maximum signal to the background is the dynamic range of the system - a measure of the useful linear range of operation. The Jove receiver dynamic range is more than 25 dB (an increase of over 300 times in antenna temperature), adequate to accommodate all but the very strongest solar bursts. However, the receiver gain and soundcard software gain controls must be set properly or the dynamic range will be reduced. Setting the gain control to the 12 o'clock position will insure a good dynamic range for the Jove 1.1 receiver.

Using Different Receivers

The Jove receiver operates over a wide dynamic range and can be used with a single point (one-step) calibration to convert SkyPipe units to antenna temperature. This calibration procedure is implemented using the calibration wizard in SkyPipe 2. The RF2080C/F one-step noise calibrator is designed for this use.

Ham radio sets can be used for Jupiter and the Sun as long as the AGC circuit can be turned off or otherwise disabled. These receivers typically incorporate a diode or product detector and may not have the wide dynamic range of the Jove receiver. In order to

convert SPU to antenna temperature, when using a ham radio receiver, it is preferable to use a calibrated hot noise source (10 million degrees or higher) followed by a 50 ohm step attenuator. Different attenuations yield different known temperatures. A calibration equation relating input temperature to SPU is then developed (for example using the curve fitting utility in Excel) and that equation is manually entered into SkyPipe.

Some observers have added an external detector and integrator circuit to their Jove receivers. If you are using one of these devices then a multi-step calibration is preferred.

Referencing the Antenna Temperature to the Antenna Terminals

For the sake of convenience we use the calibrated noise source in the observatory – right next to the receiver. Therefore, noise temperatures derived by this calibration represent temperatures at the input to the receiver. This would be fine except that different observers use different lengths of coax cable running from the antenna to the receiver. The noise temperature at the antenna terminals will always be higher than at the receiver because of coax loss. We want to take this cable loss into account and reference temperatures back to the antenna terminals. This allows a much more accurate comparison of signals received at different observatories. At a quiet receiving site the antenna temperature (referenced to the antenna terminals) will be in the range of about 40 to 80 thousand degrees. Over the course of 24 hours the antenna temperature will vary by about 3 dB (a factor of 2) as the antenna beam sweeps across the galactic plane.

Our goal is to be able to compare records with other observers, even those using different types of antennas like a Yagi or a Moxon. For those antennas the location of the antenna terminals is obvious – it is where the coax connects to the antenna structure.

But where are the antenna terminals on the Jove antenna? The Jove antenna uses coax cables connecting the two dipoles to a power combiner which is then connected to the receiver thru a single coax run.

We will define the Jove antenna terminals to be where the coax cables attach to the dipole wires – and account for all the loss occurring between the dipoles and the receiver. This includes the loss from the dipoles to the power combiner, loss in the combiner, and in the cable running to the receiver.

The Calibration Wizard

Radio SkyPipe 2 contains a calibration wizard to help you perform a single-step calibration, rescale the SkyPipe vertical axis from SPU to temperature, and reference that temperature back to the antenna terminals. The procedure is very easy, but you must know either your cable losses or type of coax cable and the length.

Before running the Cal Wizard consider the diagrams on the following page – identify your setup and determine your losses or cable type and length. In the case of the Jove dual dipole, the wizard knows the loss in the power combiner and in the cables which connect the dipoles to the power combiner. All you should enter is the loss or cable type and length from the power combiner output to the calibrator.

Jove single dipole, or any single antenna such as a Yagi, or Moxon.

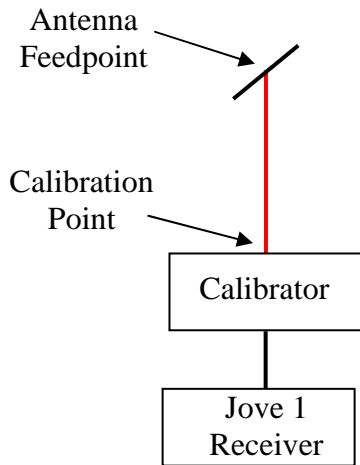

You must know cable type and length, or loss (in dB), from the antenna feedpoint to the calibration point.

Jove Dual Dipole

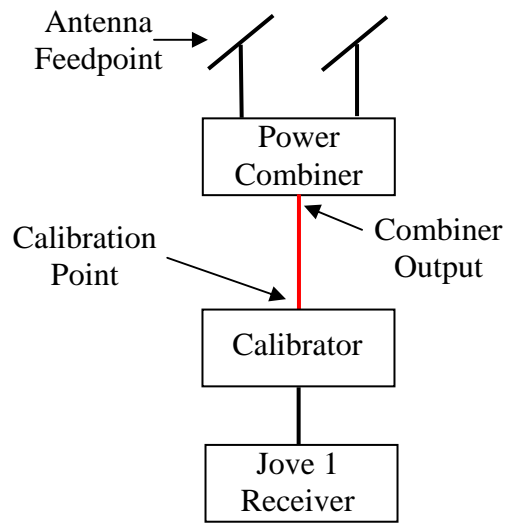

You must know cable type and length, or loss (in dB), from calibration point to power combiner output. Cal Wizard will supply loss data from the antenna feedpoint to the power combiner output.

Jove Dual Dipole with Filter

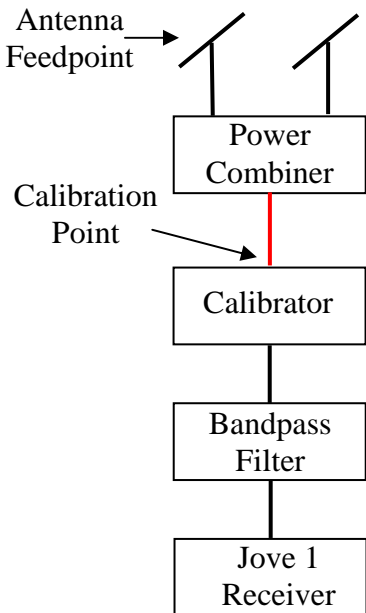

Calibrator installed between antenna and filter. Cal Wizard will supply loss data from antenna feedpoint to power combiner output.

Other

Other configurations are possible – for example a single antenna might be connected to a power splitter feeding multiple receivers. The calibrator should be installed between the antenna and specialty devices (power splitter, filters, etc). You must know cable type and length, or loss (in dB), from the calibration point to the antenna feedpoint. For reference, loss of the Jove power combiner is 0.5 dB, loss from Jove dipole feedpoint to the power combiner is 0.5 dB. At the Jove frequency of 20.1 MHz RG59 coax has a loss of 1.54dB /100' and RG6 coax has a loss of 0.84 dB /100'

The Calibrators

RF-2080 C/F

The RF-2080 is available in two versions. The RF-2080 C is a basic, calibrated, 25,000 degree noise source. The RF-2080 C/F also includes a 20.1 MHz bandpass filter which will reduce or eliminate interference to the Jove receiver caused by strong international broadcasting stations. Both models require a +12 volt power supply.



A single toggle switch controls power and also selects the source of the signal being routed to the receiver. When the 2080 is OFF the antenna is connected to the receiver. When it is ON the calibrated noise source is connected to the receiver.

The RF2080 C/F is available as a built and tested unit on the Jove website.

http://radiojove.gsfc.nasa.gov/office/order_form.html

Hot Noise Source and Multi-Step Calibrator

If you need a high temperature noise source for calibration of a receiver using a diode detector please contact RF Associates (rf at hawaii.rr.com).